

Projection of cryogenic fluids: a comparison between liquid nitrogen and liquid carbon dioxide

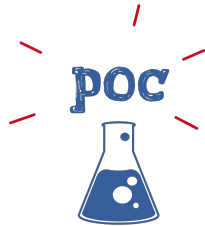

THIS DOCUMENT IS PUBLIC • OWNER

University of Twente • Nov 4, 2019

Raphaël Grandeau (R&D engineer) • Paris Innovation Campus



1

Scope of the study

Cryo-machining

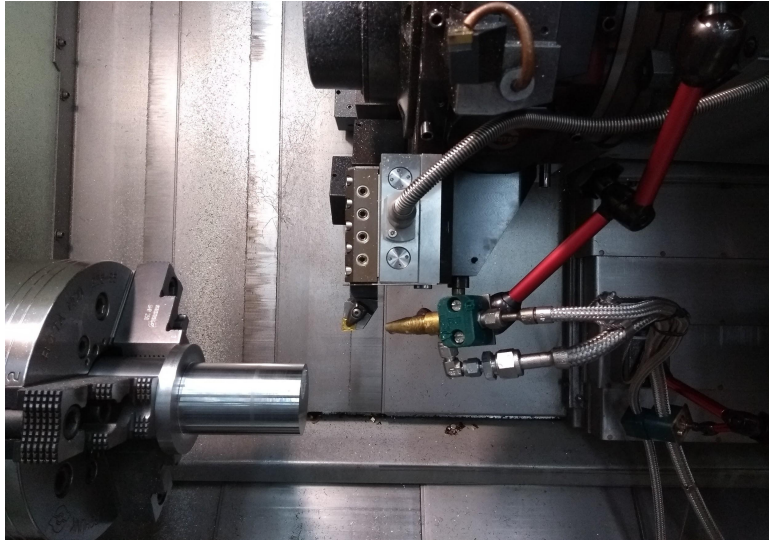

Air Liquide - turning of Ti6Al4V with CO2 + air.

THIS DOCUMENT IS PUBLIC

I

AIR LIQUIDE, THE WORLD LEADER IN GASES, TECHNOLOGIES AND SERVICES FOR INDUSTRY AND HEALTH

3

Nov 4, 2019

R. Grandeau (R&D engineer)/P. Vilain, G. Miranda (R&D interns)

Air Liquide - Paris Innovation Campus
Projection of cryogenic fluids



Cryo-machining

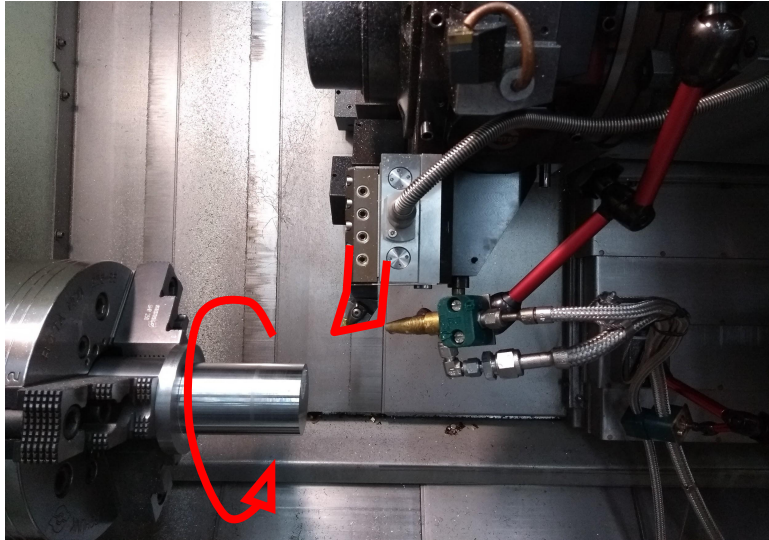

Cryo-machining

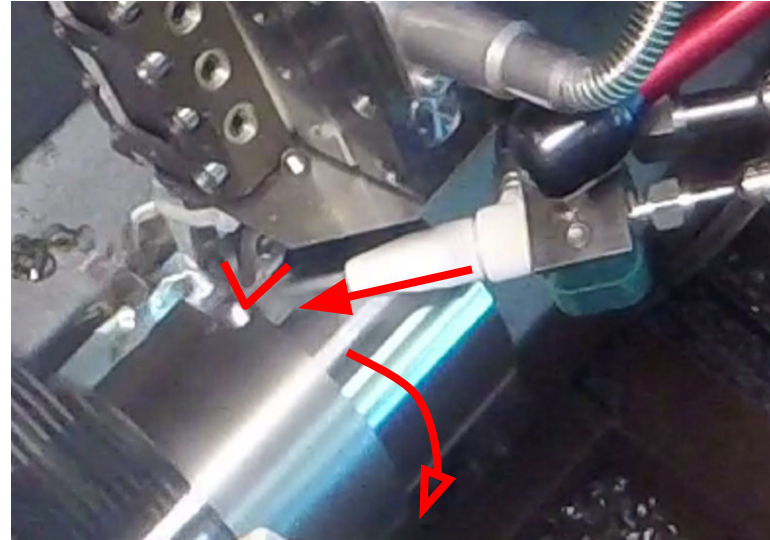
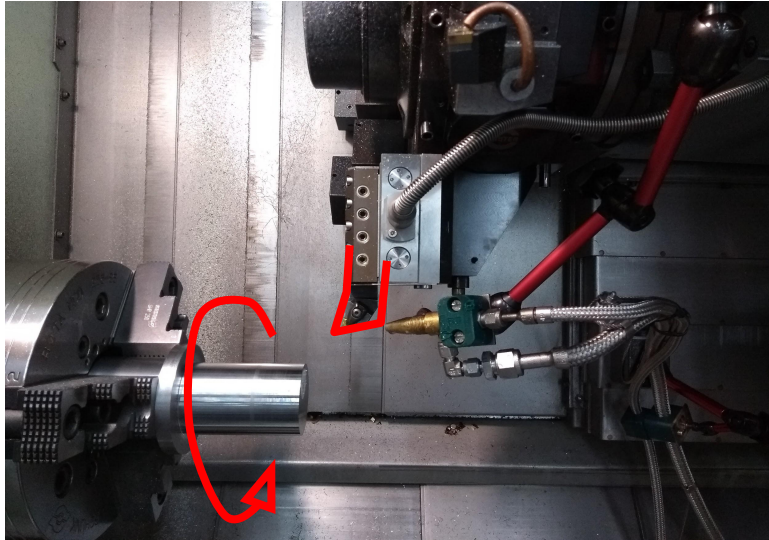

Key factors



Key factors

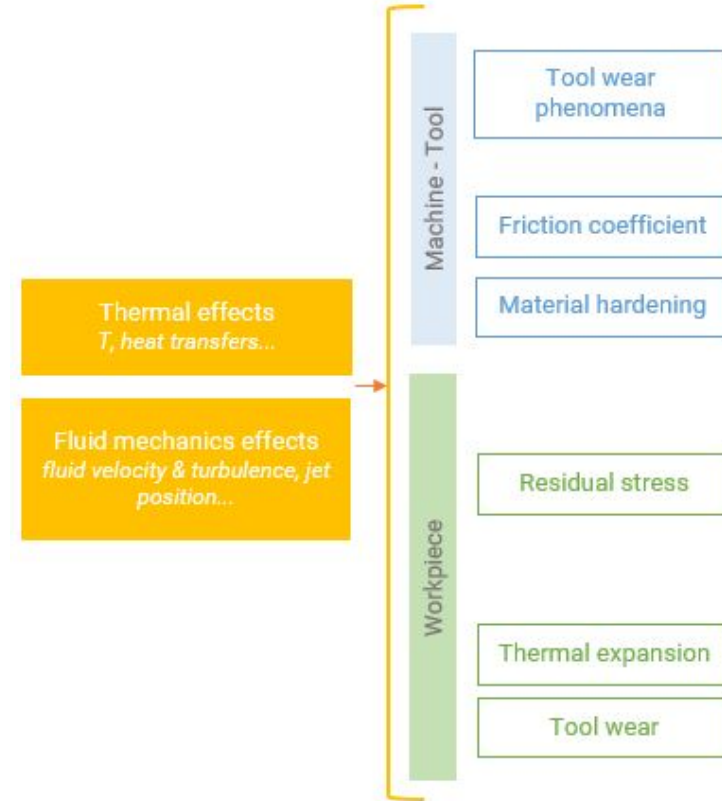

Our scope:

Experimental study of cryogenic jet impingements

Assumed:

Turning
External jet spraying



Studied:

LIN or LCO₂
Flow rate
Distance

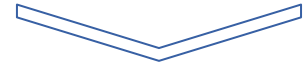

Heat transfers ?

2

Experimental set-up @ Paris Innovation Campus

Experimental set-up

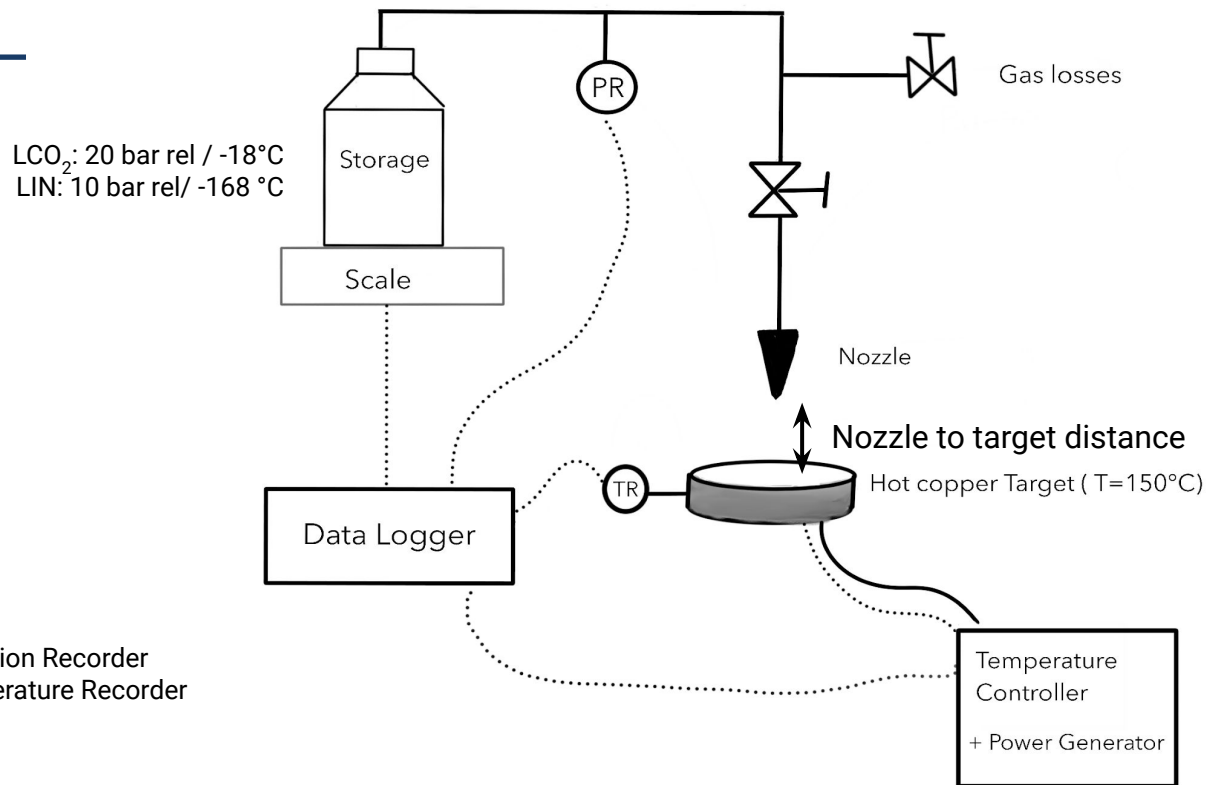

PR : Pression Recorder
TR: Temperature Recorder

Experimental set-up

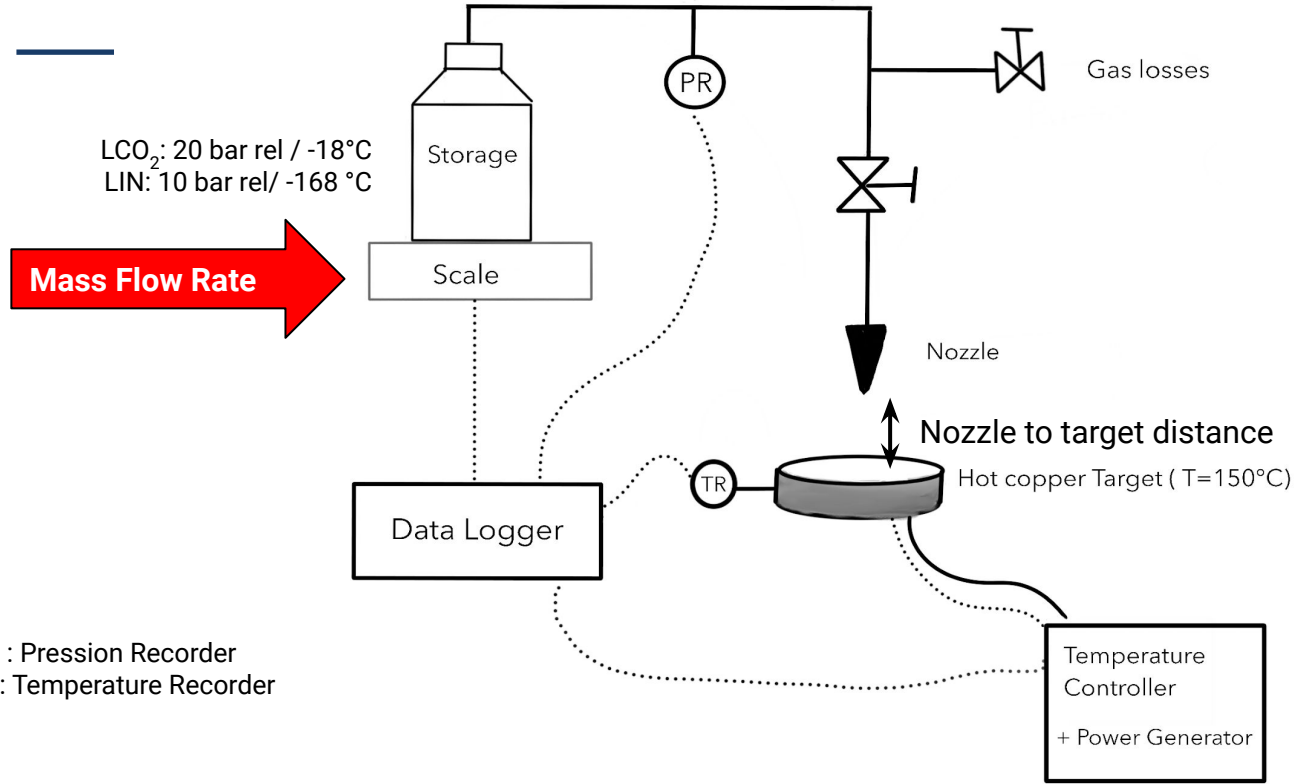

Experimental set-up

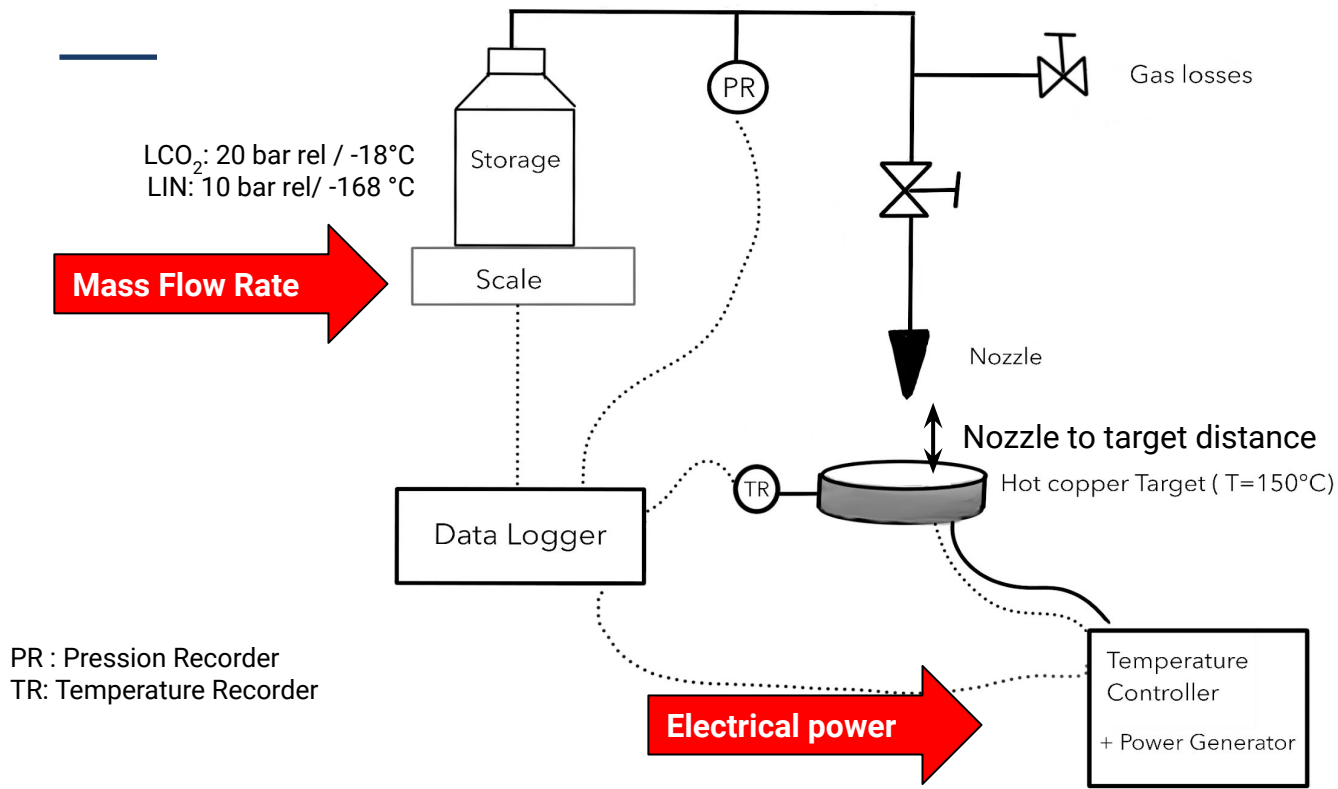

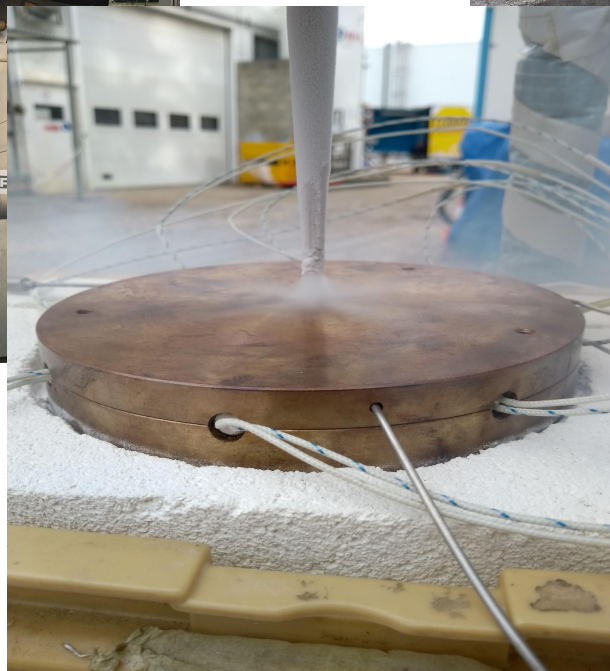

Air Liquide - Paris Innovation Campus

THIS DOCUMENT IS PUBLIC

I

AIR LIQUIDE, THE WORLD LEADER IN GASES, TECHNOLOGIES AND SERVICES FOR INDUSTRY AND HEALTH

13

Nov 4, 2019

R. Grandeau (R&D engineer)/P. Vilain, G. Miranda (R&D interns)

Air Liquide - Paris Innovation Campus
Projection of cryogenic fluids



3

Experimental results

LIN vs. LCO₂: Flow Rate Through the Nozzle

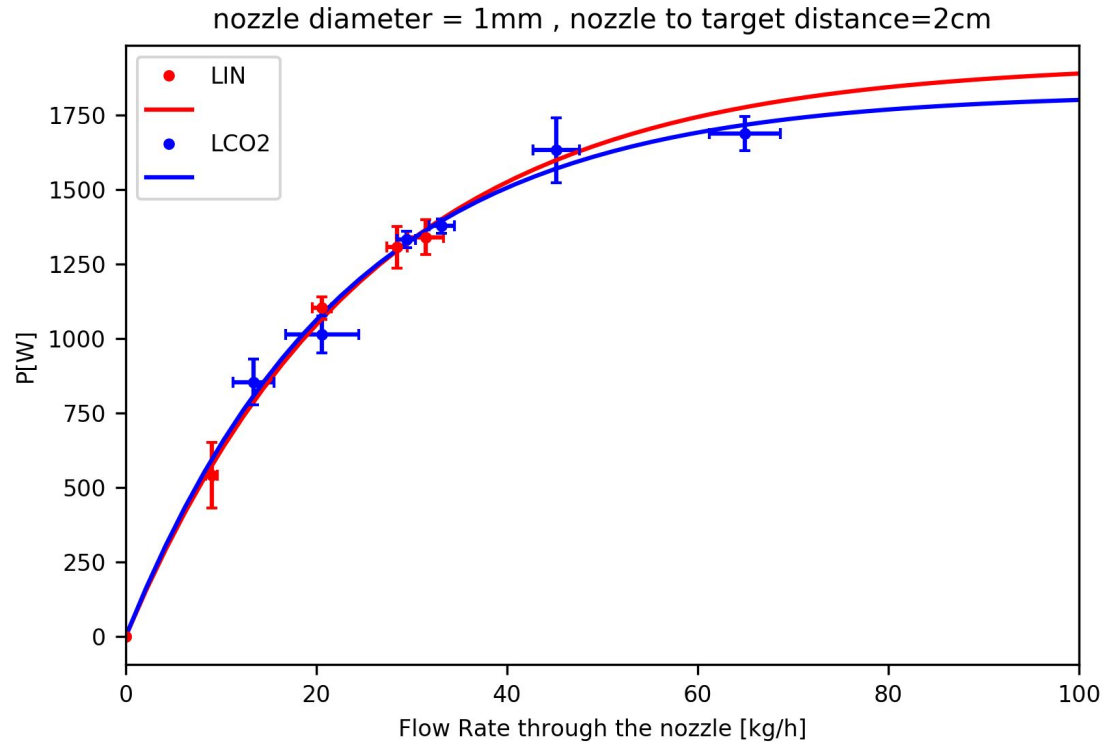

Influence of the nozzle to target distance

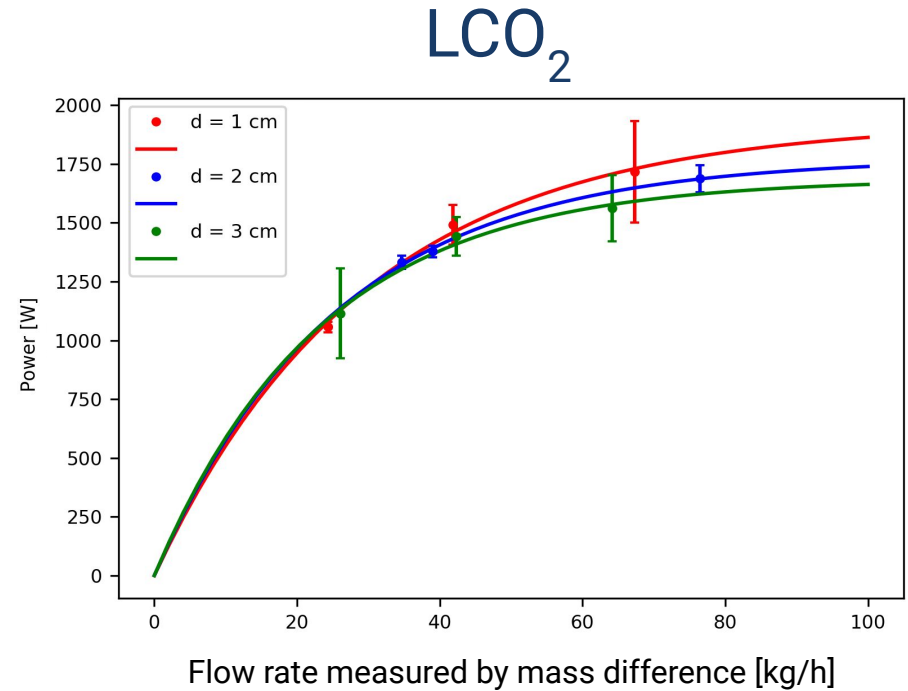
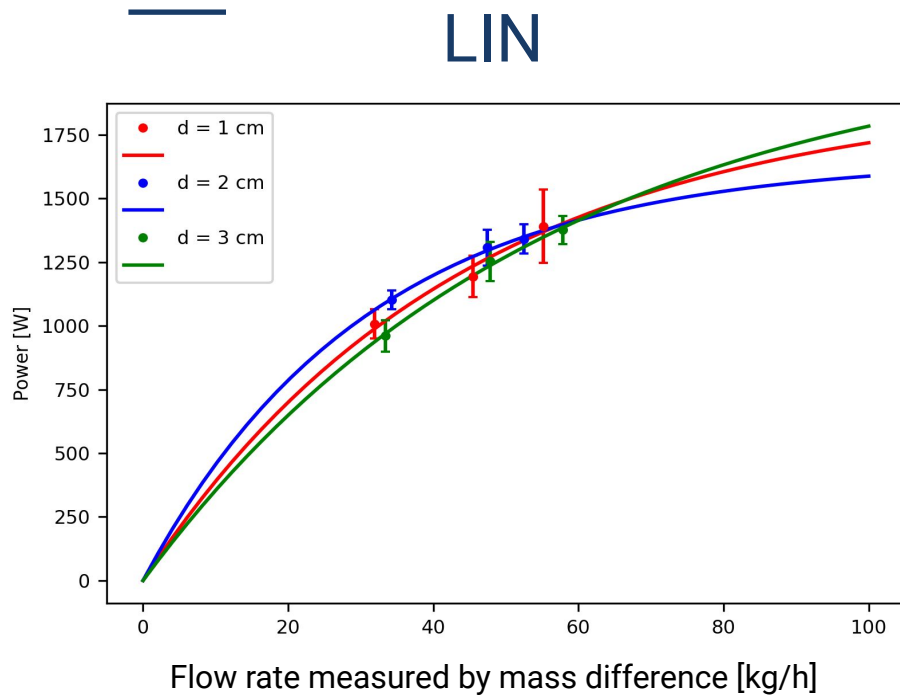

Conclusion

Assumed:

Turning
External jet spraying



Studied:

LIN or LCO₂
Flow rate
Distance



Heat transfers ?

Thank you



encyclopedia.
airliquide.com



Air Liquide

site.airliquide.com/rd



linkedin.com/
groups/8449228



Raphaël Grandeau

R&D Engineer

raphael.grandeau@airliquide.com